

## Cubola forms

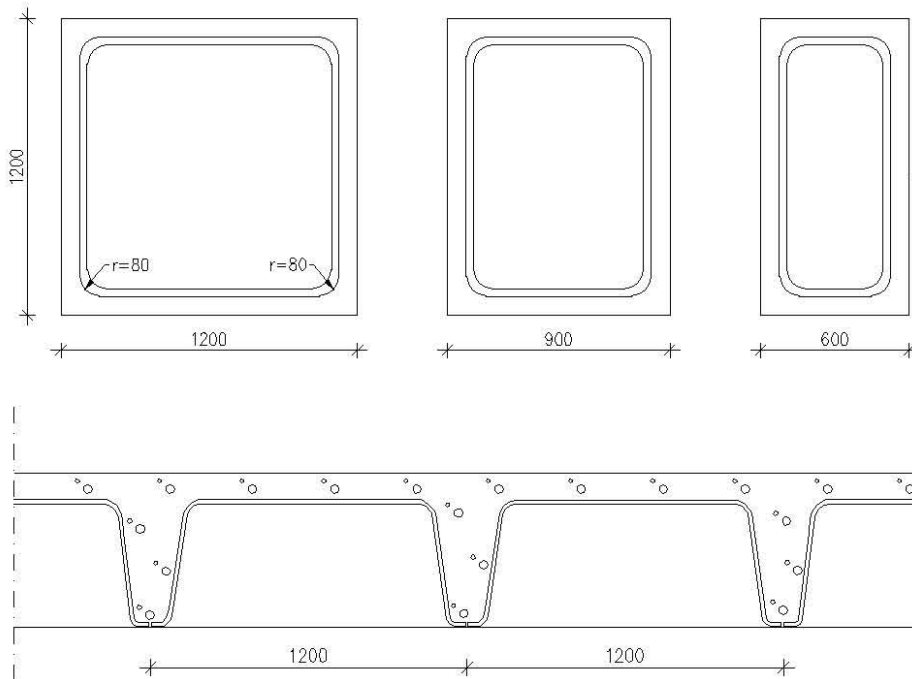

Collar in forms 75 mm

### Standard sizes

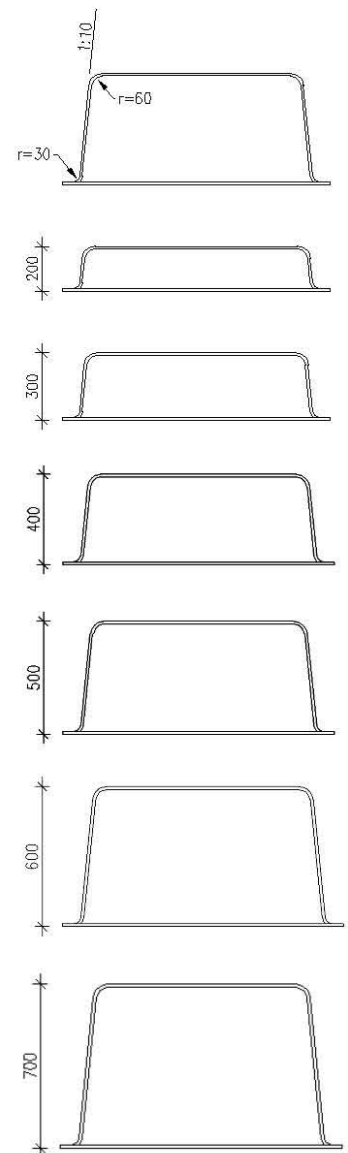

Cubola form	C16/20	C25/30		C40/50	C50/60	
	K20	K30	K40	K50	K60	K70
Weight kg/pc	23	28	35	45	50	55
Concrete cons. hl=100 m <sup>3</sup> /m <sup>2</sup>	0,15	0,18	0,22	0,25	0,29	0,39
Dead load hl=100 m <sup>3</sup> /m <sup>2</sup>	360	432	528	600	696	936
Span m load 4 kN/m <sup>2</sup>	8,4	10,8	12,0	14,8	15,6	18,0
Rib width mm, c/c 1200 mm	150	150	150	150	150	200
Economical span 7,2 m ... 18 m						

### **Finn Form** Cubola forms - Economical construction

- Economical midsole structure
- Quick installation and destruction
- Light, but consistent and supporting structure
- Smooth and first-rate concrete surface
- Form oil saving surface
- Low transport and handling costs
- Economic leasing prices

Good acoustic characterist and attractive visual feature.  
Also with special measurement.